



Designing an Electromagnetic Shield to Block Secondary Cosmic Rays

Shreyas Agarwal, Faith Dennis, Storm Lin, Siddhant Mehrotra, Richard Wang, Brent Zhao

PI: Yasmeen Musthafa Mentors: Michael Oshiro, Joe Singh, Adrien Stejer

University of California, Berkeley



Introduction

Neutrinos are extremely light, electrically neutral leptons which only interact through gravity and the weak force. Due to their lack of charge, neutrinos can pass through most forms of matter. Neutrinos form from nuclear reactions in supernovas and stars (Ahmad et. al, 2001). Solar neutrinos are those which originate from the nuclear reactions within the Sun, and every second, approximately 65 billion solar neutrinos pass through a square centimeter. Most current forms of neutrino detection take place deep underground in large tanks of water, surrounded by photomultiplier tubes (PMTs), to escape background noise from showers produced by cosmic rays and radiation.

Among the particles produced in cosmic ray showers are muons, a type of charged lepton. Muons are produced with various momenta, and this determines their probability of reaching sea level. Muons with momenta around 100 GeV have a 97% probability of surviving to sea level (Allkoibf et. al). Their presence compromises the detection of neutrinos (Tanaka et. al, 2007). Muons are used as a metric for shielding against secondary cosmic rays.

One distinction between neutrinos and particles which compose cosmic rays and radiation is that they are electrically neutral. By exploiting this characteristic, it may be possible to construct neutrino detectors that are not deep underground. A prototype electromagnetic shielding apparatus and muon detector were designed and tested to observe how effective muon deflection is.

The implemented design shields from muons through a combination of natural metallic materials and a magnetic field produced by an arrangement of electromagnets and neodymium magnets. The metals implemented were chosen through a simulation which utilized the Bethe Equation (1) to parse through the periodic table and select elements with the characteristics required to obtain the desired change in energy. Based on practicality and financial feasibility, our design utilized a collection of aluminum and steel to reduce the muon energy (Figure 2). This setup only required the generation of a magnetic field under 1 Tesla which was obtainable with a current of 5-10 A and neodymium magnets (Condotti, 2013).

$$-\left\langle \frac{dE}{dx} \right\rangle = \frac{4\pi}{m_e c^2} \cdot \frac{n z^2}{\beta^2} \cdot \left(\frac{c^2}{4\pi\epsilon_0} \right)^2 \cdot \left[\ln \left(\frac{2m_e c^2 \beta^2}{I \cdot (1 - \beta^2)} \right) - \beta^2 \right] \quad (1)$$

$$n = \frac{N_A \cdot Z \cdot \rho}{A \cdot M_u}$$

To assess the effectiveness of the muon shield, a small scale muon detector was constructed (Figure 6). The detector is composed of a PMT coupled with a scintillator, a charge sensitive amplifier, and a microcontroller wired to a laptop. A Photonis XP5312 PMT, supplied with 1000 V, detects photons emitted from a BC408 plastic scintillator and outputs a current. The amplifier (Figure 7) provides a gain of a factor of 10 and extends the pulse width to allow the Mega 2560 Microcontroller to record voltages at rate within its capabilities. The data from the serial monitor is processed through an analysis software written in Python.

The experimentation took place in the basement of Birge Hall at UC Berkeley. Experimentation was conducted over three trials. The first trial served as a control where the detector was completely uncovered. The second was under a metal barrier with a thickness of approximately 20-23 cm. The third was a combination of the metal barrier and magnetic field produced by neodymium magnets and electromagnets (Figure 1). The electromagnets were toroids wrapped with 24 gauge copper wire and powered by a 9 V supply. The neodymium magnets were positioned in a Halbach Array.

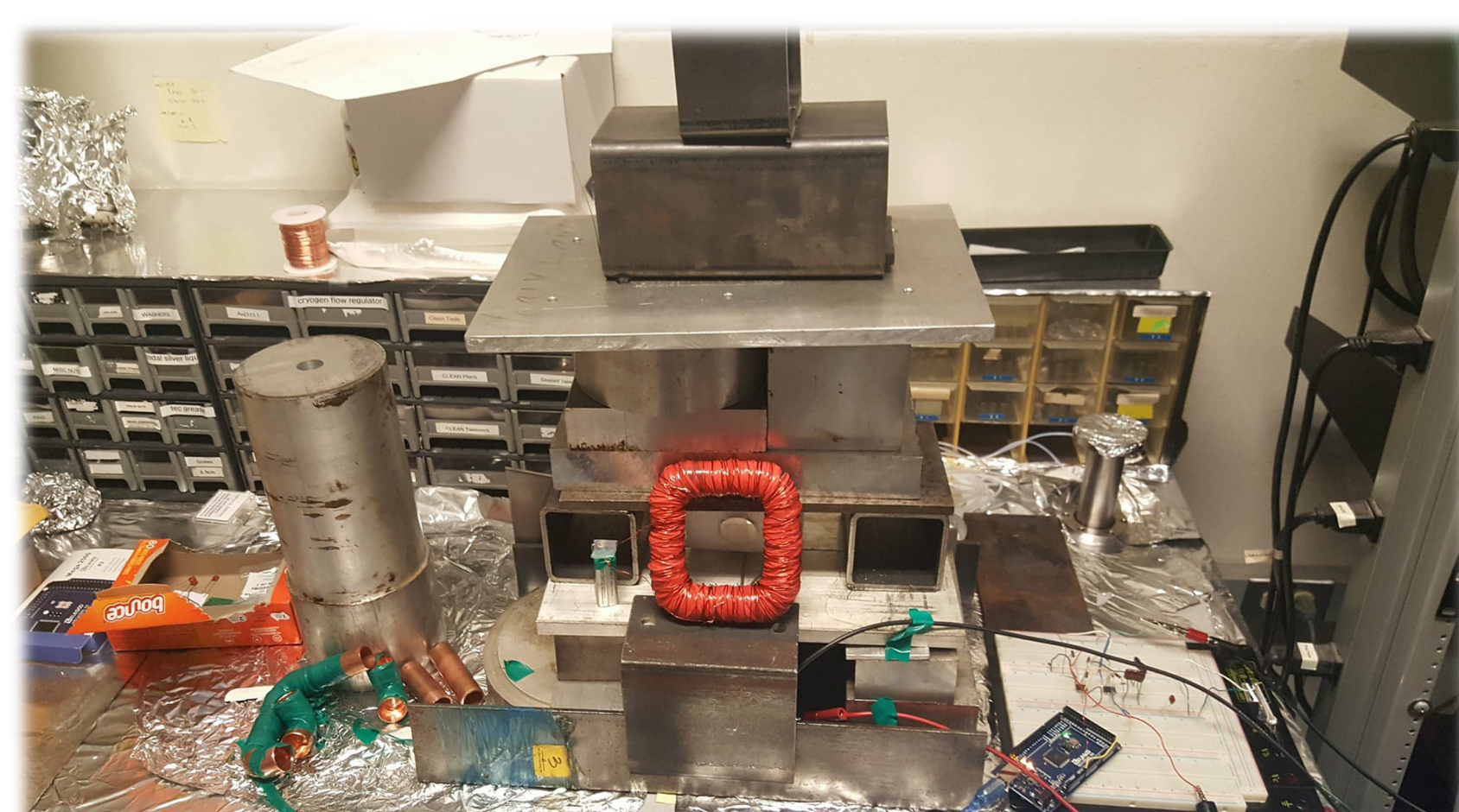

Figure 1: Experiment setup for the third trial. The PMT is under the neodymium magnets and electromagnet and the 20-23 cm metal barrier. Photographed by Siddhant Mehrotra, April 20th, 2018.

Muon Energy Loss vs Distance into Material

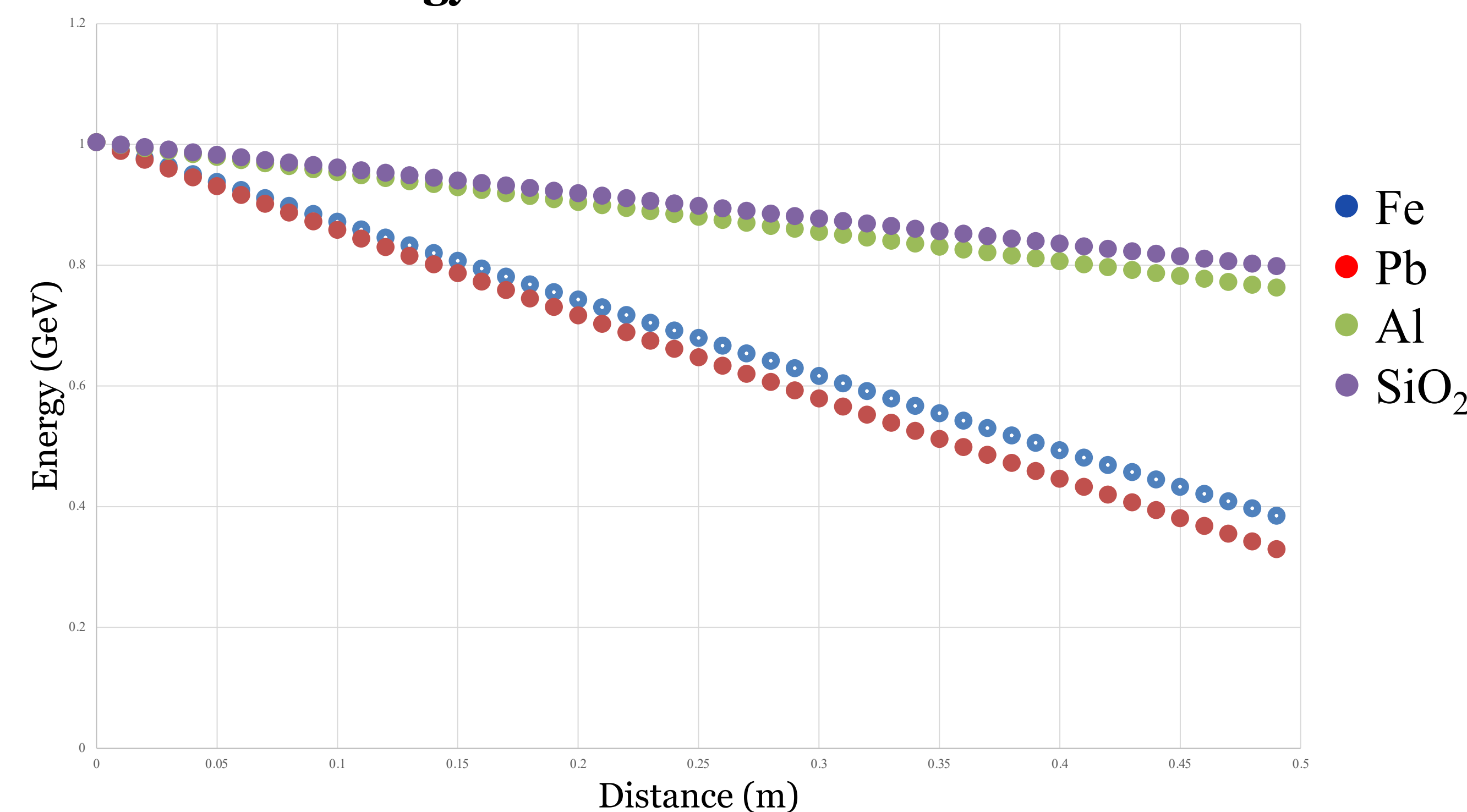

Figure 2: Using Bethe Equation to plot loss of energy over distance for Iron, Lead, Aluminum, and Silica.

Control (No Shield)

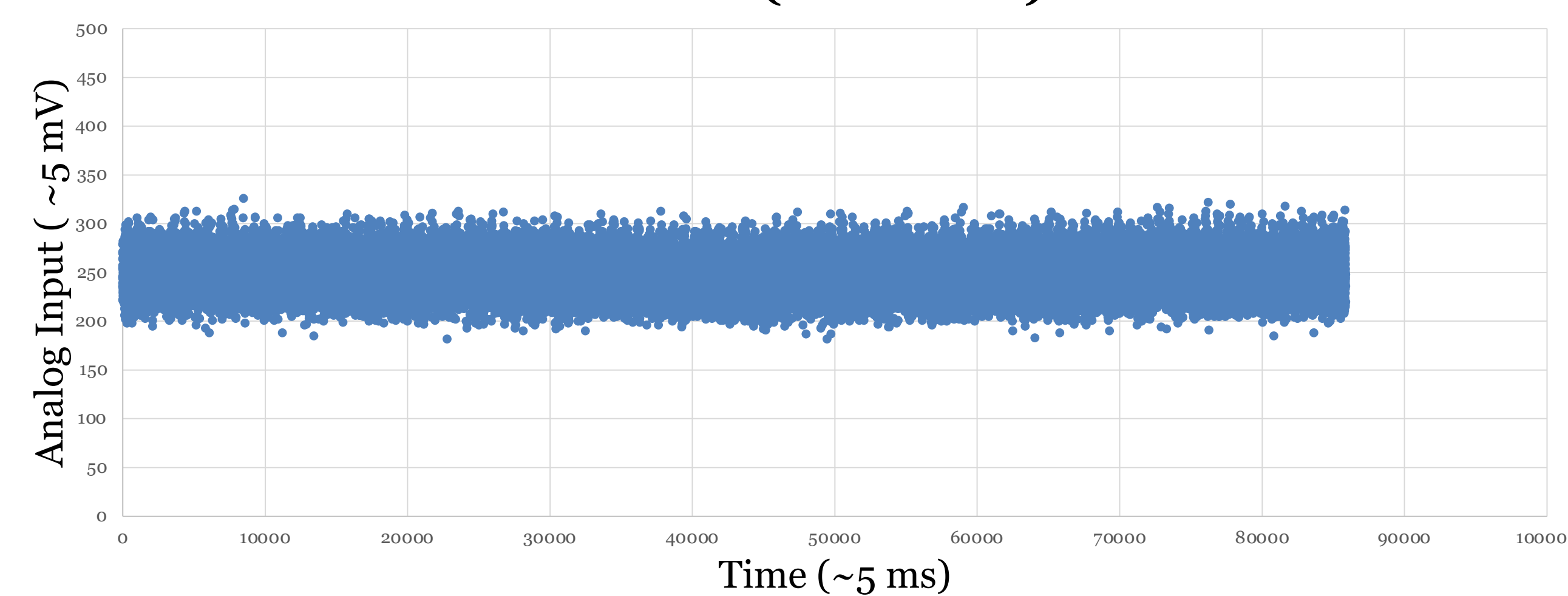

Figure 3: Data from Trial 1

Metal Shield Only

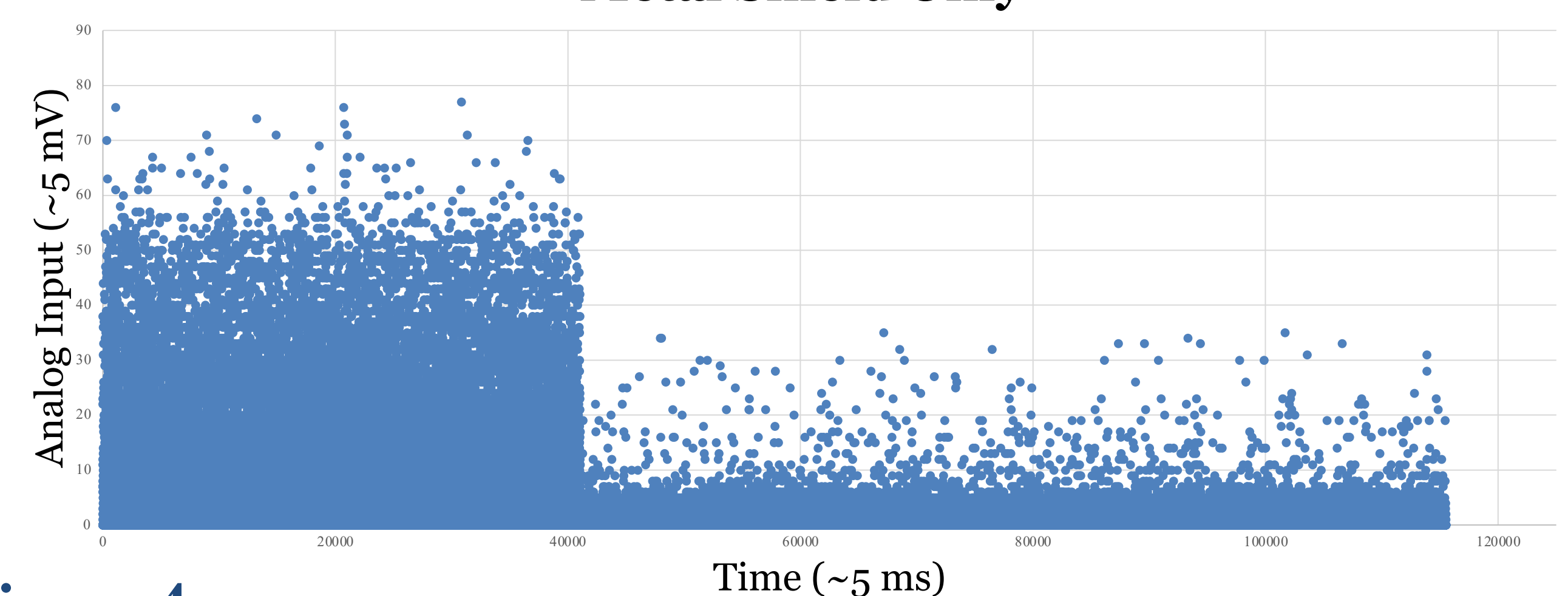

Figure 4: Data from Trial 2

With Magnets and Metal Shield

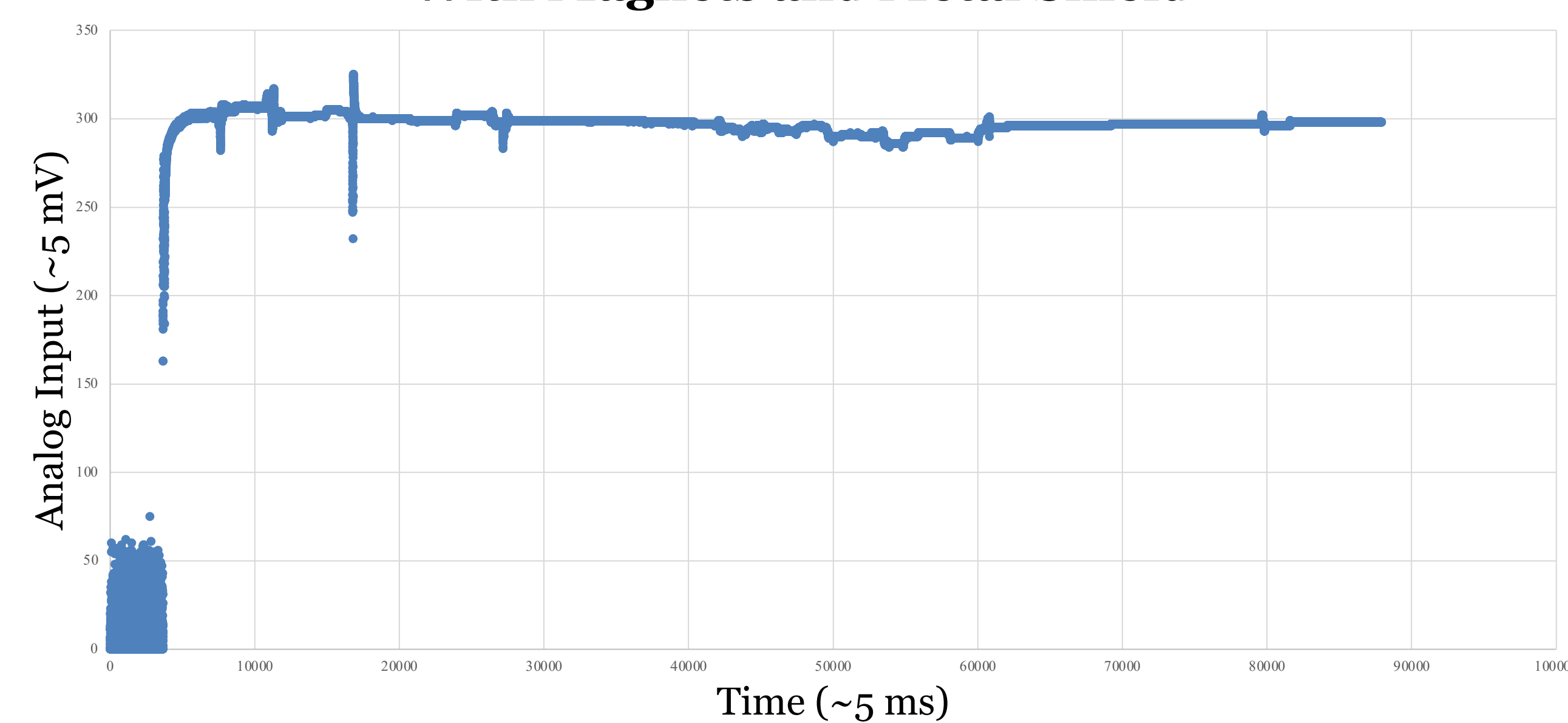

Figure 5: Data from Trial 3

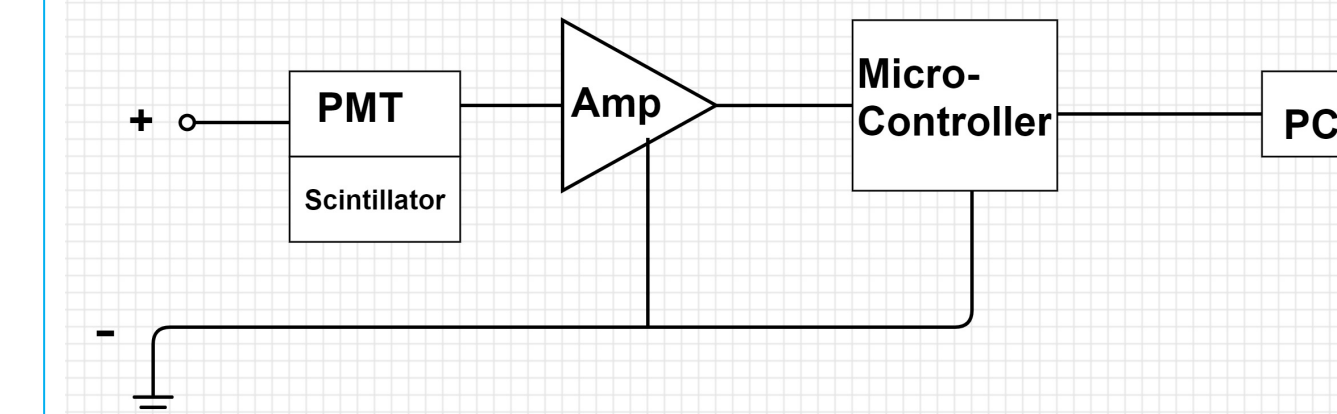
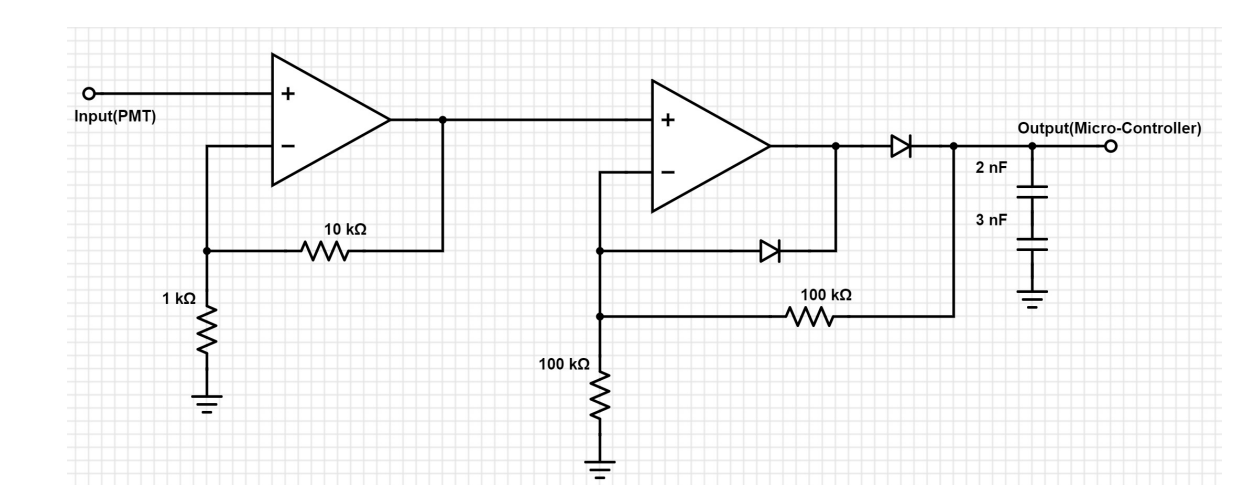

Figure 6: Block diagram of detector

Figure 7: Charge sensitive preamplifier



Analysis

The control trial (Figure 3) showed a regular and contained distribution centered at around 250 (~1.25 V) varying by about 50 (~0.25 V). Data points with a value above 1024 (~5 V), are outside the range of the input port and are rejected as a software error.

These datasets do not have any obvious spikes or other features that may indicate muon detections. The first trial of this set was strikingly different from the others, suggesting that it occurred under different circumstances. The data suggest a small amount of light was leaking into the PMT, causing the observed signal and masking any signal from muons.

The trial with only the metal shield (Figure 4) showed a dense distribution of points from 0 to 30 (0 to ~0.15 V) with some points up to about 80 (~0.4 V). However, after around point 40,000 (~200 s), the distribution changes abruptly. Most of the points after were between 0 and 5 (0 to ~0.025 V) with only a few up to a maximum of about 40 (~0.2 V). This sharp “cliff” was likely caused by a problem in the electronics. Again, the distribution did not have any features which would suggest muon detections.

The trial with both metal and magnetic shielding (Figure 5) initially showed a distribution that was dense between 0 to 25 (0 to ~0.125 V) with few points up to about 80 (~0.4 V). At around point 5,000 (~25 seconds), the distribution rises dramatically but smoothly. It settles at around 300 (~1.5 V) with very little variance except for a few vertical “spikes.” These voltage spikes, extending upward and downward, could indicate muon detections. It should be noted that the data from the microcontroller with no input settles at around 325 (~1.5 V) with little variance, suggesting that this sudden rise might have again been an electronic failure and the spikes may not be meaningful.

Conclusion & Future Work

The objective of this experiment was to engineer a device for muon detection as well as a system for reducing the muon flux through an area using magnets and physical shields in order to facilitate the detection of other particles. After a design, testing, and revision process, a final system for detection and shielding was developed and assembled. During data collection and analysis, a python script that used numpy and matplotlib was used to analyze and plot the data. Due to potential problems with electronics, further experimentation is required to make a more accurate statement on the practicality of such a design. Future investigations would entail further debugging as well as an increased run time for each trial.

Acknowledgments

Thank you to UC Berkeley and ULAB including Arjun Savel, Kim Ambrocio, Zachary Sweger, Erika Hearts, Jessica Tin, Amit Akula, and Yasmeen Musthafa for providing the opportunity to do this research. Also thank you to Edgar Ibarra and the Crommie Lab for providing a voltage source and area to work.

Ahmad, Q. R., Allen, R. C., Andersen, T. C., Anglin, J. D., Bühler, G., Barton, J. C., ... & Black, R. A. (2001). Measurement of the Rate of $\nu e^+ d \rightarrow p^+ p^+ e^-$ Interactions Produced by B 8 Solar Neutrinos at the Sudbury Neutrino Observatory. *Physical Review Letters*, 87(7), 071301.

Allkoibf, O. C., & Kiel C, G. K. Cosmic Ray Muons.

Condotti, A., Wiseman, W., (2013) Bending Muons Deflecting Muons Through The Use of Magnetic Fields, [website]

Tanaka, H. K., Nakano, T., Takahashi, S., Yoshida, J., Takeo, M., Oikawa, J., ... & Niwa, K. (2007). High resolution imaging in the inhomogeneous crust with cosmic-ray muon radiography: The density structure below the volcanic crater floor of Mt. Asama, Japan. *Earth and Planetary Science Letters*, 263(1), 104-113